

630 x 630 Corner Wall Unit

Panels

Tools Required

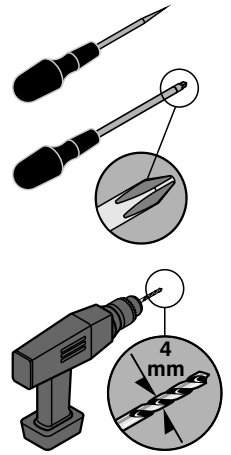
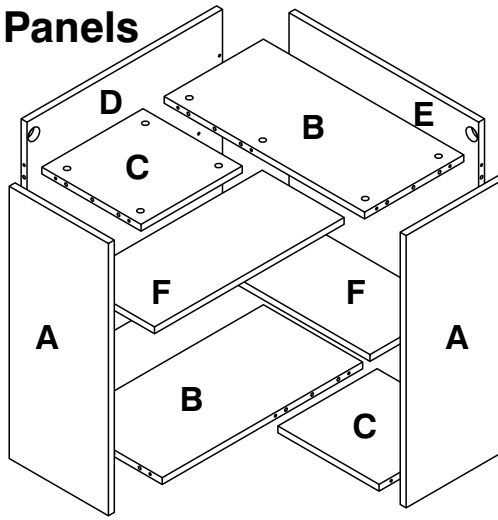
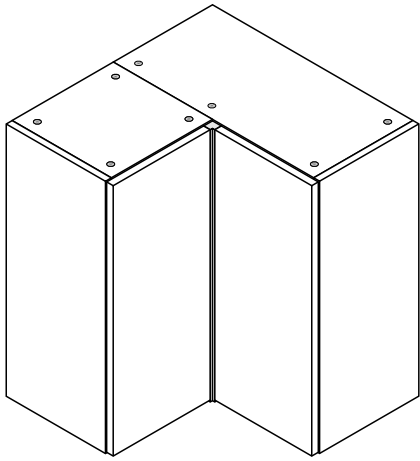

Hardware Quantities

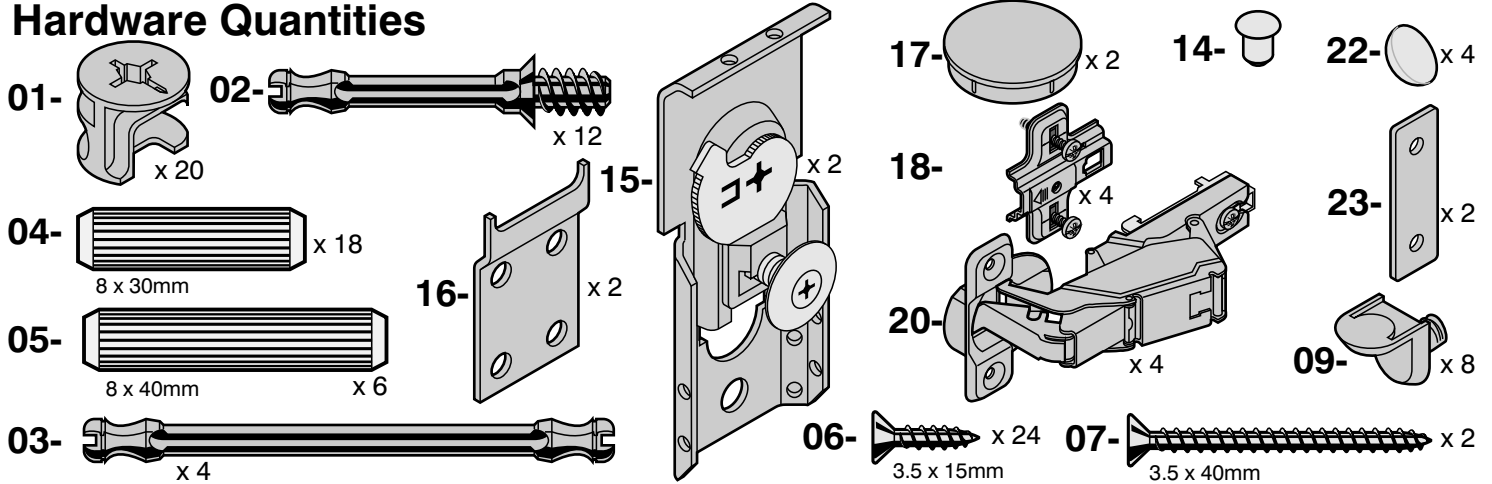

STEP 1

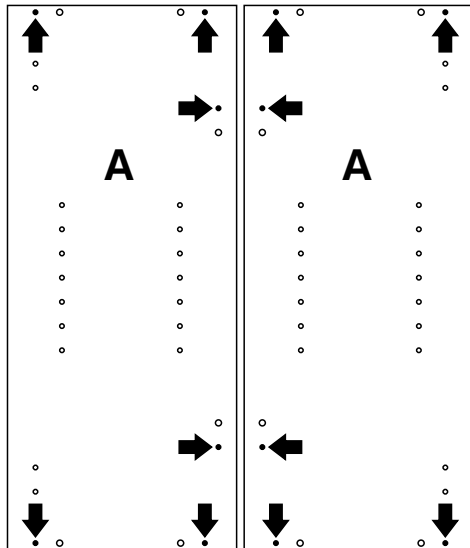

STEP 2

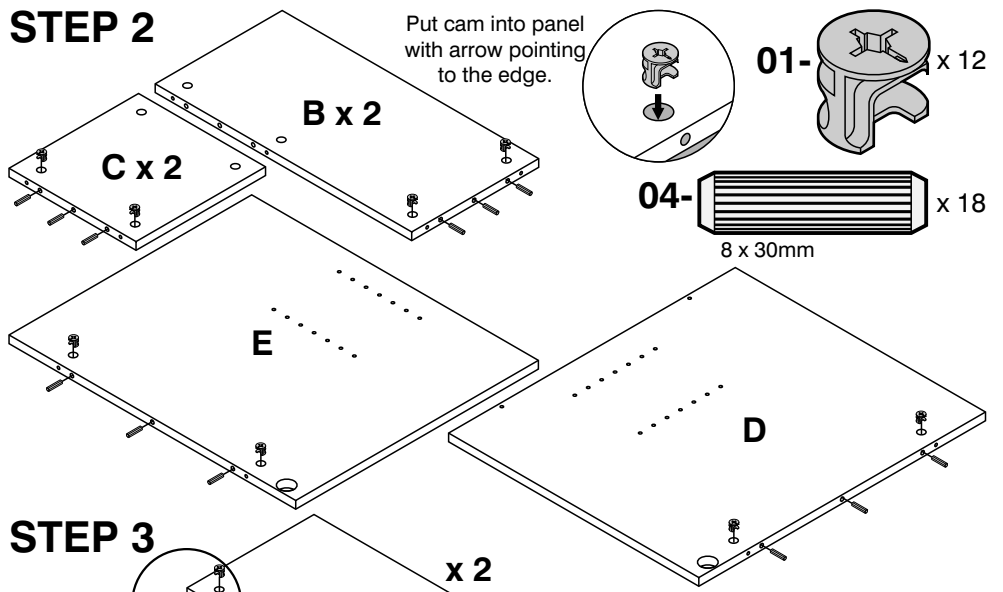

STEP 3

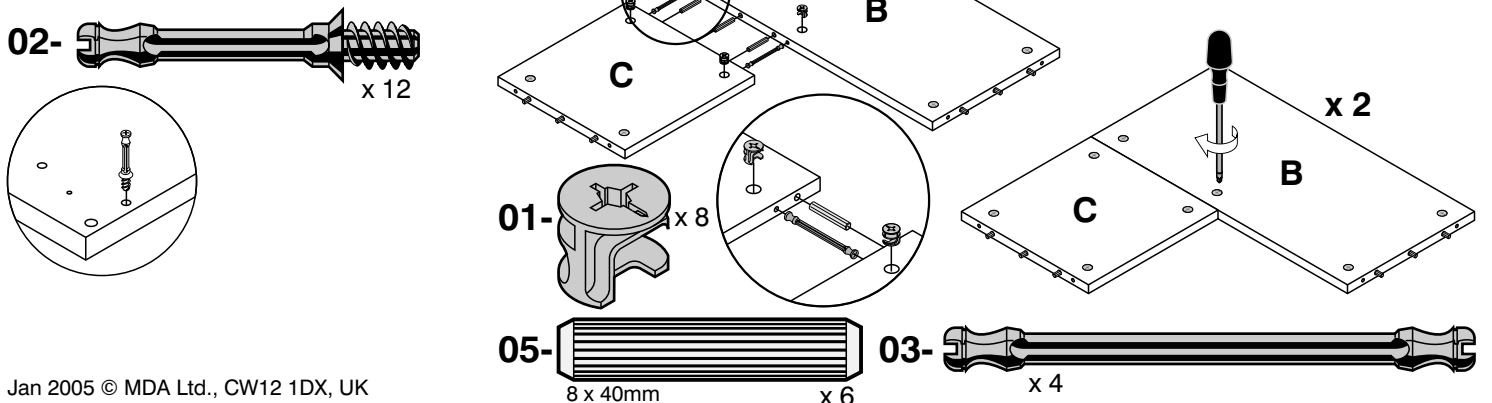

STEP 4

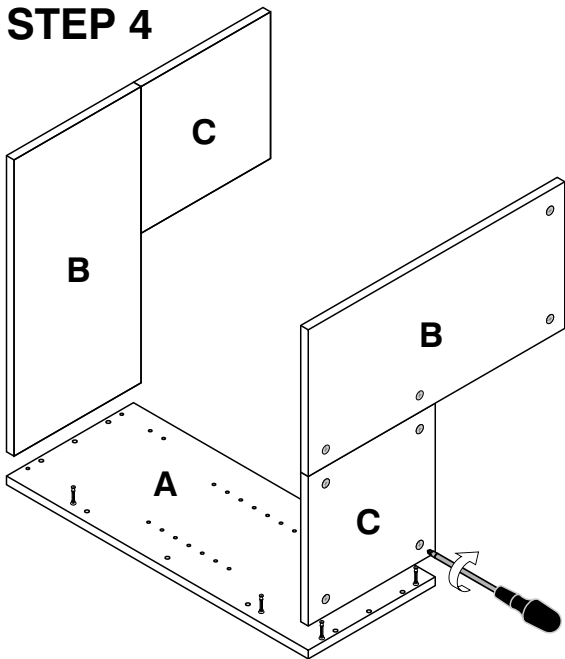

STEP 5

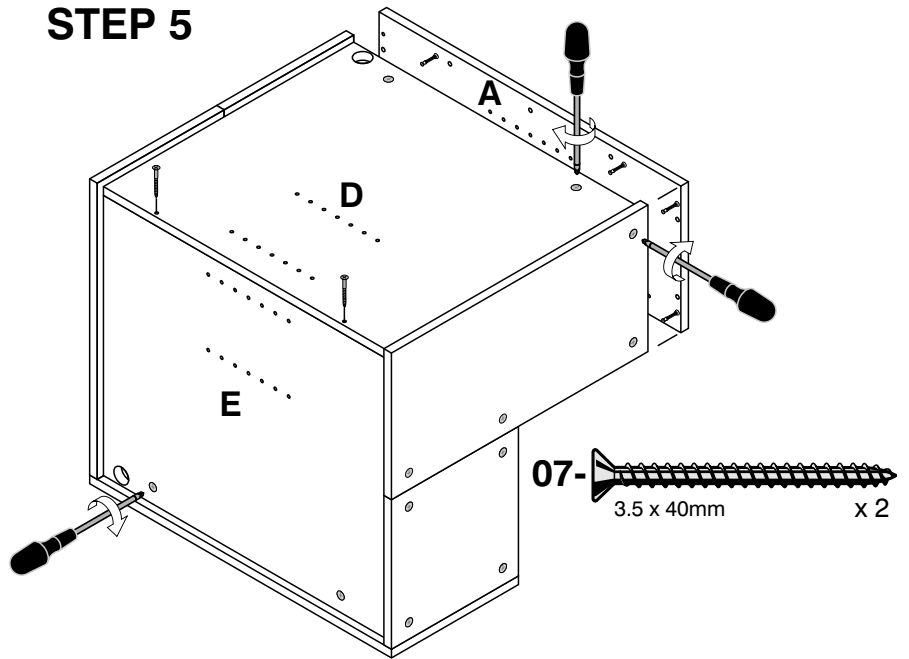

STEP 6

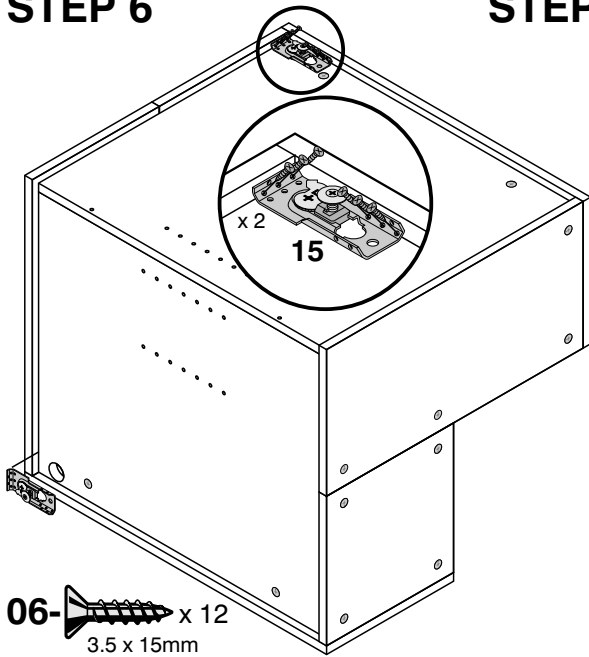

STEP 7 IMPORTANT: Please refer to the hob manufacturer's instructions for information regarding the minimum distance allowed between the hob and wall units.

NOTE: Measurement is to the bottom of the plate (16). Attach the plates (16) securely to the wall using the most appropriate fixings (not supplied).

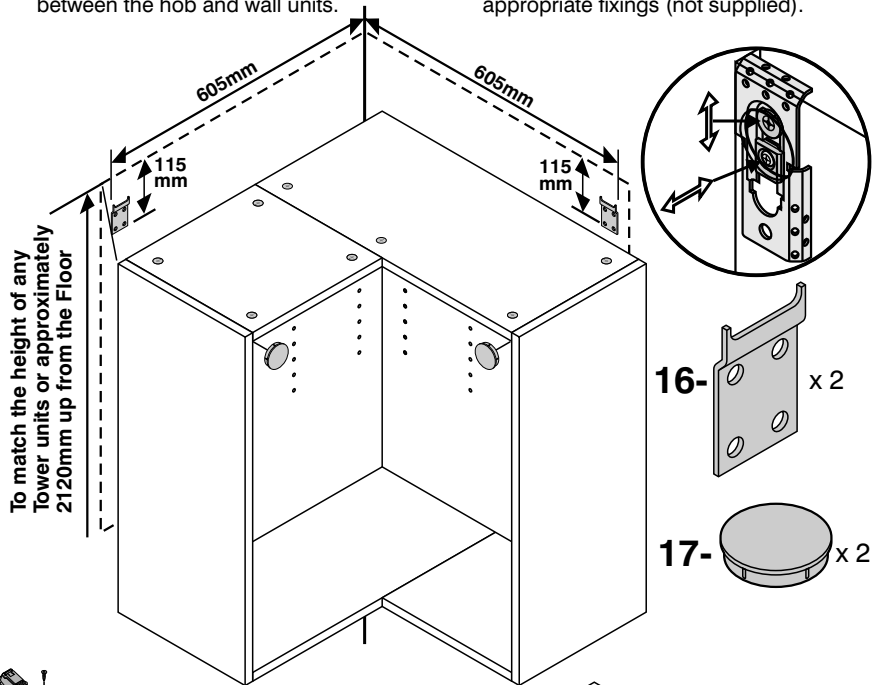

STEP 8

Clip the hinges together.

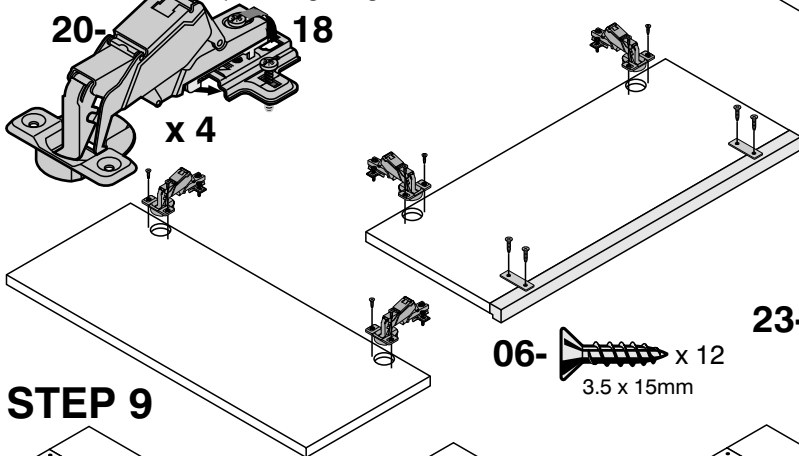

STEP 9

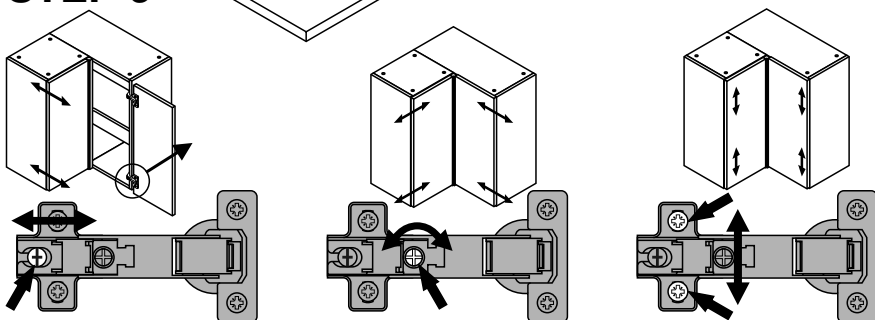

STEP 10

